

Universal Control AF-1

User's Manual

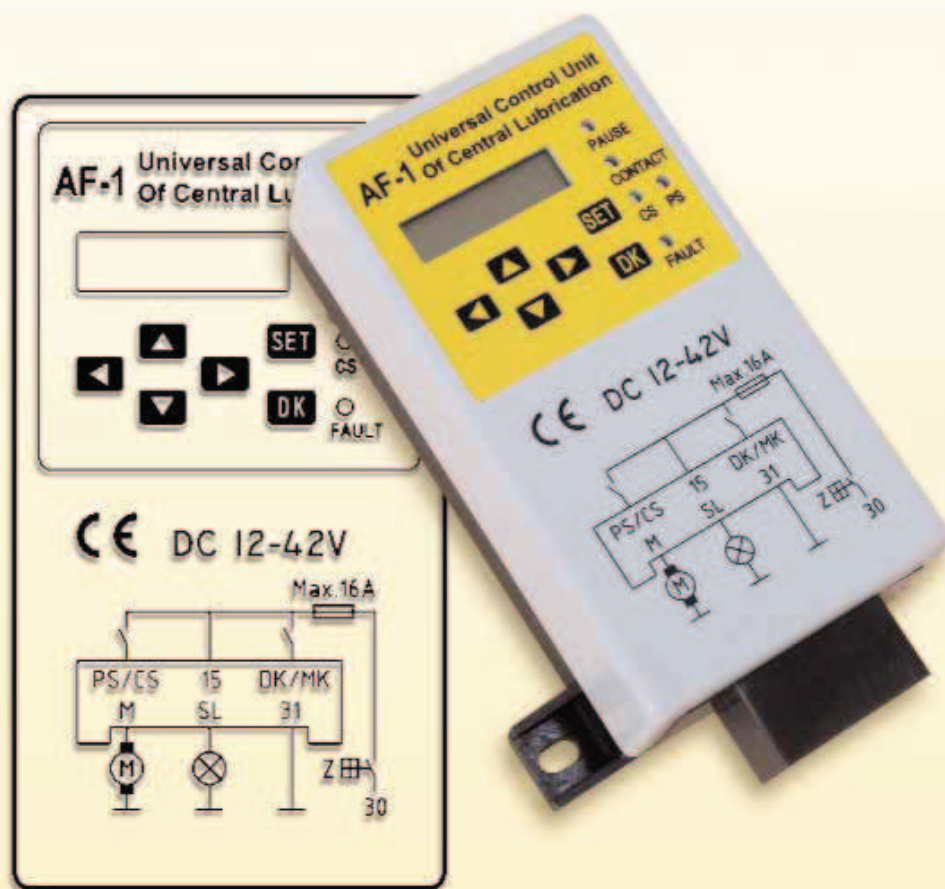

Fritsche GmbH

www.fritsche-gmbh.de
www.centrollubrication.com

Impressum

Universal Control Unit AF-1 is designed for controlling and monitoring of centralized lubrication systems of engineering machinery, chassis and lubrication stations.

AF-1 stores configuration data and parameters in EEPROM, which made AF-1 can store data safely for long period without backup power supply. The control unit use LCD to display information.

Factory settings on AF-1 are as followings:

Pause mode:	timer
Pause time:	9 h
Contact mode:	timer
Contact time:	2min 36s (2.6min)
Initial password:	0000
System monitoring:	Pressure Switch

Model's instruction

Universal control Unit AF-1 10V ~ 45V

wide voltage, suitable for 12V, 24V and 36(42)V rated voltage,

English interface

Without our written permission, any forms of translation, excerpt, copy, print and reproduce of this USER MANUAL and its content is prohibited. We reserve all rights to this USER MANUAL. We reserve the right to revise it without prior notice.

Fritsche GmbH Verwaltung
Niedersachsenweg 36
D-21244 Buchholz
Phone +49 (0) 4187 600 770
Fax +49 (0) 4187 600 779
Fritsche-gmbh@t-online.de
www.fritsche-gmbh.de

Fritsche GmbH Werk
Eichenhöhe 4-5
D-21255 Kakenstorf
Phone +49 (0) 41 86 88 82 90
Fax +49 (0) 41 86 88 82 999
www.centrollubrication.com

Contents

Safety Warning!

1. Installation
 - 1.1 Installation dimensions
 - 1.2 Electrical connection

2. Display and control panel
 - 2.1 LCD display
 - 2.2 LED signal lights
 - 2.3 Keys
 - 2.4 SL signal lights

3. Display mode
 - 3.1 Display operation

4. Programming
 - 4.1 Start programming mode
 - 4.2 Modify pause and/or contact parameters
 - 4.3 Change system monitoring settings
 - 4.4 Change pause and/or contact control modes
 - 4.5 Change password

5. Operating modes
 - 5.1 Timer operation
 - 5.2 Counter operation
 - 5.3 Combination operation
 - 5.4 Operation without system monitoring
 - 5.5 Operation with system monitoring
 - 5.6 Power-off protection function

6. Faults
 - 6.1 Fault display
 - 6.2 Fault message clearance
 - 6.3 Block operation
 - 6.4 No signal from pressure switch
 - 6.5 Fault message storage

7. Technical data

Safety Warning!

Universal Control Unit AF-1 is designed and manufactured not only in conformity with the generally engineering standards, industrial safety and accident prevention regulations, but also in accordance with some relevant generally industrial technical acceptance standards. Although this unit complies with relevant safety technical requirements, the use of the unit may still entail dangers leading to personal injury of the user or third parties or damage to property. Therefore, the unit must be used when it is in perfect technical condition. And the operation must strictly comply with operation manual. Errors that may affect safety must be rectified immediately.

The unit is designed for controlling and monitoring centralized lubrication systems. The user himself shall be liable for any damage caused by improper use.

Potential electrical dangers

This unit must be connected to the power supply only by trained qualified personnel in accordance with the local electric technical regulations. Improper connection may lead to serious personal injury.

This unit is designed to use in battery-powered on-board electric system of chassis, engineering equipment and lubrication station. When it is used for any other purposes, all safety regulations should be complied with.

Qualified personnel

Qualified person means person trained, assigned and instructed by the operator of the equipment concerned. They are familiar with relevant safety rules or regulations and have certain knowledge and skills of safety.

They are entitled to carry out the activities required in a given case and will be able to recognize and avoid possibly existing dangers.

1. Installation

Universal Control Unit AF-1 is not designed to work in open-air; it has to be installed in an enclosed compartment to protect it from environmental influences.

If the control unit is installed at an inaccessible position, it is advisable to install additional signal lights and illuminated pushbutton in operation room. So that the operating situation of the control unit can be remote monitored.

1.1 Installation dimension

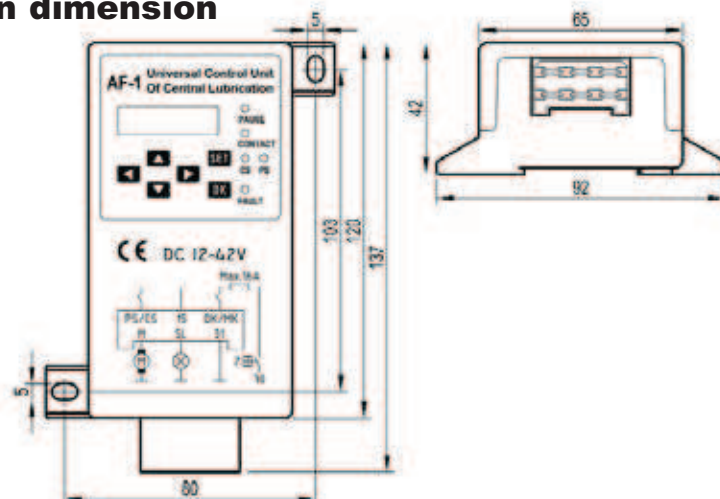

1.2 Electrical connection

PS / CS	External Pressure Switch or Cycle Switch
15	Positive pole of power supply of AF-1
M	Pump Motor
SL	External Signal Light
DK / MK	External Pushbutton (timer operation)
	Signal Input (counter operation)
31	Ground
Z	Start switch

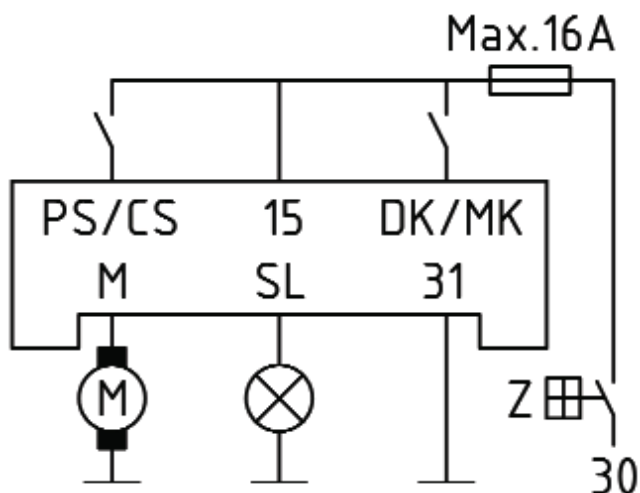

Note:

Universal Control Unit AF-1 is a wide voltage model for 12V, 24V and 36(42)V.

Please make sure that the system voltage matches the voltage claimed on the control unit. The fluctuation of supply voltage should be within power voltage limit range. Lower or higher than the voltage limit will permanently damage the control unit.

If the lowest required voltage is not guaranteed, please purchase Low Voltage Protector to protect the control unit against low voltage.

Terminal connection diagram

Electrical connection of external illuminated pushbutton diagram

2. Display and control panel

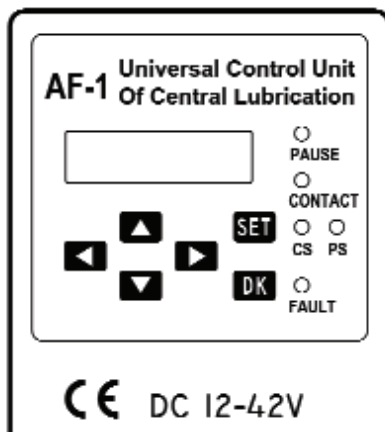



Film panel protects AF-1 from humidity and dust. Please use soft cloth with warm water or neutral detergent to clean the film panel. Organic solvent is prohibited because the film is made in organic material. Do not use sharp tools/ object to touch the panel.

2.1 LCD display

CONTROL UNIT
SN: 07010001

LCD displays operating status and parameters.

It is deactivated normally. To activate it, press ke  or  LCD then start to display current status and programmed parameters.*

2.2 LED signal light



CONTACT

CONTACT: Lubricating signal light

LED "CONTACT" an: Stromversorgung zur Pumpe und Steuergerät. (Pumpenbetrieb)

LED "CONTACT" is on: Power is supplied to pump and control unit.

System is in CONTACT status. (Pump motor is running) LED "CONTACT" is flashing:

1. Control unit is in CONTACT programming mode. The value and control mode of CONTACT can be altered.
2. When CS (Cycle Switch) monitoring is activated, LED "CONTACT" and "CS" will be alternate flashing and control unit is in drive phase of a block operation.



PAUSE

PAUSE: Pause signal light.

LED "PAUSE" is on: Power is supplied to pump and control unit. System is in PAUSE status. LED "PAUSE" is flashing:

1. Control unit is in PAUSE programming mode. The value and control mode of PAUSE can be altered.
2. When **C**ycle **S**witch monitoring is activated, LED "PAUSE" and "CS" are flashing alternately. Control unit is in PAUSE phase of a block operation.

 CS CS?External Cycle Switch signal light

LED "CS" is on: A Cycle Switch is used for monitoring the system. Monitoring the progressive distributor during the pump running time.
LED "CS" is flashing:



1. Control unit is in monitoring programming status. At this status, the mode of monitoring can be altered; Cycle Switch monitoring can be activated or deactivated.
 2. When CS (Cycle Switch) monitoring is activated, LED "CONTACT" (or "PAUSE") and LED "CS" will be alternate flashing and control unit is in block operation.
-

 PS PS?External Pressure Switch signal light

LED "PS" is on: A pressure switch is used for monitoring the system. Monitoring pressure during pump running time.



LED "PS" is flashing: Control unit is in monitoring programming status. At this status, the mode of monitoring can be altered; the Pressure Switch monitoring can be activated or deactivated.

 FAULT FAULT: Fault signal light

LED "FAULT" flashes quickly: Control unit is in fault.
Press key  or , then fault message will be displayed on LCD.

2.3 Keys

 Scroll up or down key

Scroll up or down key  or decrease with key  the displayed value at cursor position by 1 in programming mode.** Press key  to roll up the menu in menu operation.

  Scroll left or right key

To move the cursor position when input parameters in programming mode.

 SET key

Activate programming mode. Confirm entered values or option.



Draining oder cleared Key

During PAUSE time, to initiate an intermediate lubrication cycle by pressing **DK** once. In FAULT status, operate this key to clear fault message and get system back to normal lubrication cycle.

2.4 External Signal Light SL

If an external signal light SL has been installed, SL will flash for 3 seconds after the start-switch is started.

Note: Control unit needs a certain time to save the operating parameters at the point of power-down so that the lubrication task of the control unit could be continued after the break.

The interval of the power-down and the next power-on should not be shorter than 3 seconds. Otherwise, control unit may not start properly, and SL will not flash.

Whenever the control unit is performing the lubrication task, light "SL" will be on, indicating the status of lubricating; If the detecting system detects any faults during operating process, light "SL" will be flashing to remind user that the lubrication system is in fault.

* Under display mode or programming mode, if no key operations for more than 2 minute, LCD turns off automatically and quit current operation.

** When using key or to alter parameters, control unit will refuse to perform the change if the new parameter is out of the programmable range of the control unit. In such cases, please check your operation.

3. Display mode

Briefly press key or to activate display. The current values and the preset parameters are displayed.

During normal operation, LED signal lights are used to show current status of the control unit.

3.1 Display operation

1. Briefly press key or to activate display mode and to show control unit's **Serial Number** *

Example: 07010001

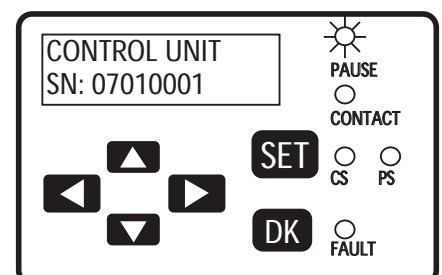

2. Press key , to show the current operating status of the control unit.

Example: PAUSE & TIMER MODE
(Pause time in timer mode)

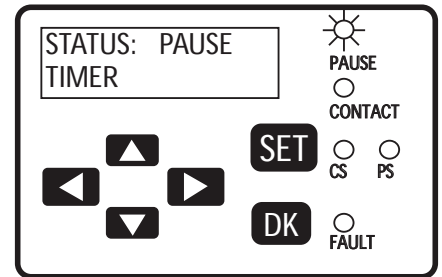

3. Press , displays the remaining pause time.
Example: 006h 48min

If PAUSE is set in counter mode, a number will be displayed.

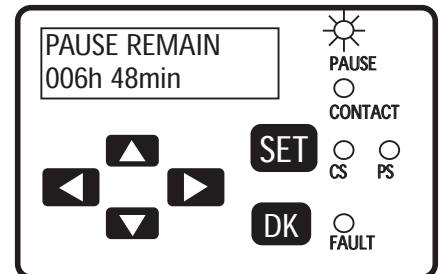

4. Press , displays preset parameter of pause time.
Example: 009h 00min

If PAUSE is set in counter mode, a number will be displayed.

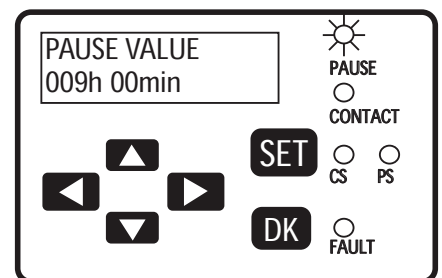

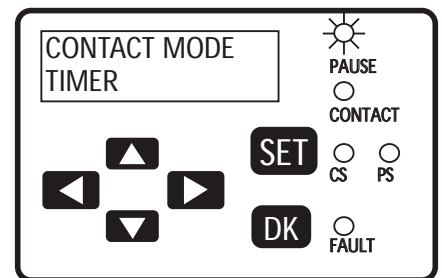

5. Press , displays the control mode of CONTACT.
Example: TIMER

(The control mode of Pump is Timer)

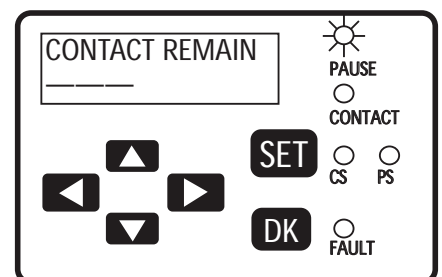

6. Press , "— — —" is displayed. Because system is now in PAUSE time, there is no remaining value of CONTACT.



7. Press , displays preset parameter of CONTACT.
Example: 00h 02min 36s

If CONTACT is set in counter mode, a number will be displayed.

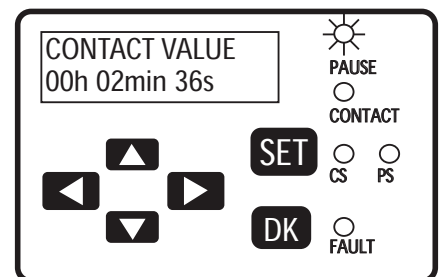

8. Press **▲** to display system monitoring.
 Displayed content may be:
PRESSURE SWITCH
 (Monitoring via pressure switch.)

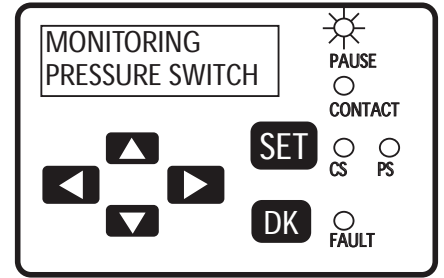

or **CYCLE SWITCH** (Monitoring via cycle switch.)

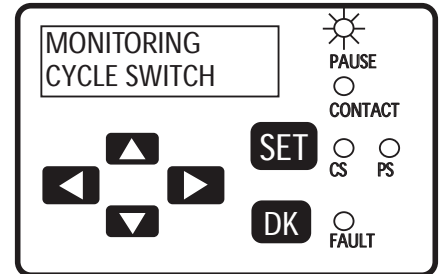

or **OFF**
 (Monitoring disabled)

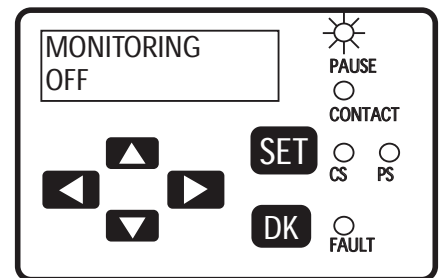

9. Press **▲**, displays total operation time.
 Example: 000533h 48min
 Maximum value: 999999h 59min

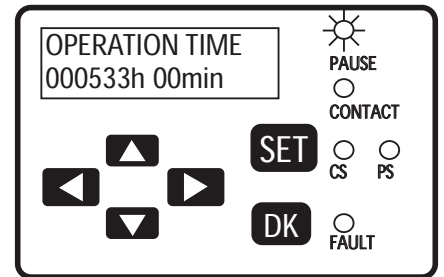

10. Press **▲**, displays total fault time.
 Example: 000033h 48min
 Maximum value: 999999h 59min

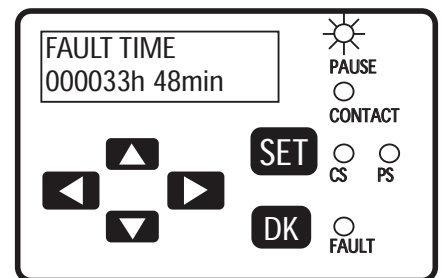

11. Press **▲**, display goes out.
 Total operation time and total fault time will not be erased. They are permanently stored in EEPROM.

* This function is set according to EU's regulations. According to relevant EU directives, electronic product for EU market must own an only serial number, which enables to trace and manage the product.

4. Programming

Press **SET** longer than 2 seconds to activate programming.
All preset parameters and control modes can be altered.
Please note: Programming always starts with steps 1-2.

4.1 Starts programming

1. Press **SET** longer than 2 seconds, the control unit will then ask for password.
Please enter the preset password.

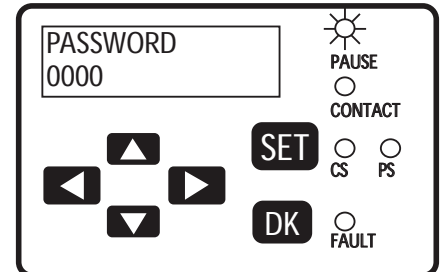

2. Press **SET** to confirm the password. LCD now displays PROGRAMMING. And the default operation is "SET PARAMETERS".

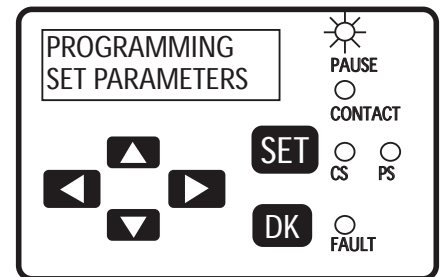

4.2 Alters pause and contact values (Carry out steps 1-2)

3. Briefly press **SET** to display the preset PAUSE value.
LED "PAUSE" flashes.
Example: 9 h (Factory setting)

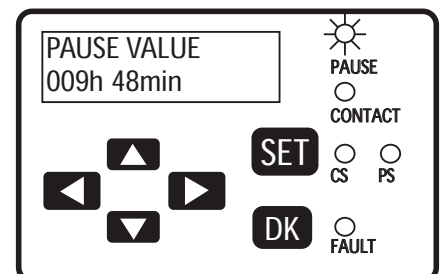

4. Use keys **▲▼◀▶** to set new pause value.
Example: new value is 6 hours and 48 minutes.

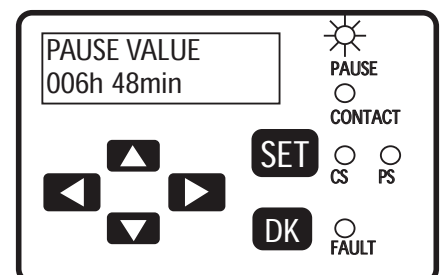

5. Press **SET** to confirm the new PAUSE value.
LED "PAUSE" goes out and LED "CONTACT" Flashes.
The preset contact value is displayed
Example: 2min 36s (Factory setting)

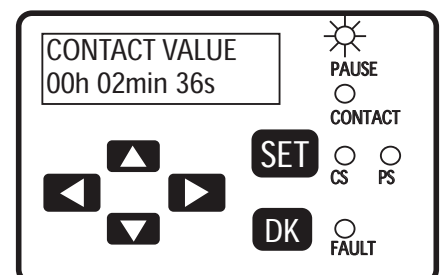

6. Use keys     to set new contact value.
Example: new value is 3 minutes.

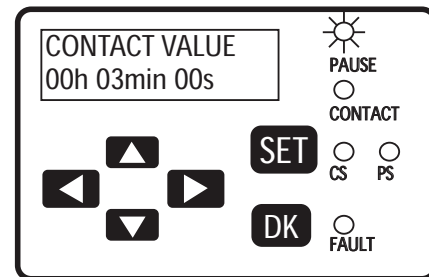

7. Press  to confirm the new contact value.

8. LCD flashes to remind user all new values are confirmed. Then press  without releasing, LCD stops flashing; 2 seconds later, the new values are saved permanently and display goes out.

Note: If press  shorter than 2 seconds, the control unit will give up new values and go back to the initial state of PROGRAMMING.

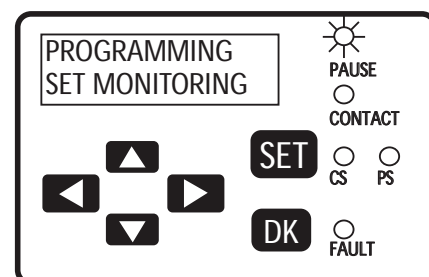

4.3 Change system monitoring settings (Carry out steps 1-2)

3. Continually press  till "SET MONITORING" is displayed on the second line of the LCD and LED "CS" and "PS" are flashing

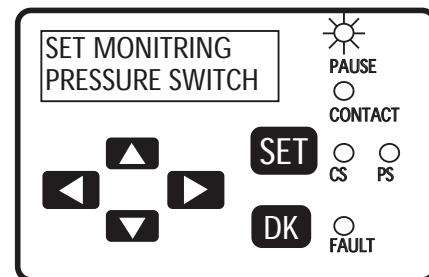

4. Briefly press  to get into system monitoring setting status. The current monitoring mode is displayed.
Example: PRESSURE SWITCH
Monitoring via pressure switch. (Factory setting)



5. Press  or  to select monitoring mode.
Example: LED "CS" flashes, "CYCLE SWITCH" is selected.
(Monitoring via cycle switch)

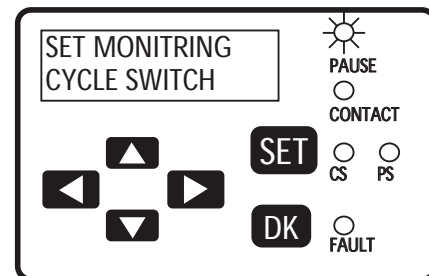

or select "OFF" to deactivate system monitoring.
(LED "CS" and "PS" goes out)

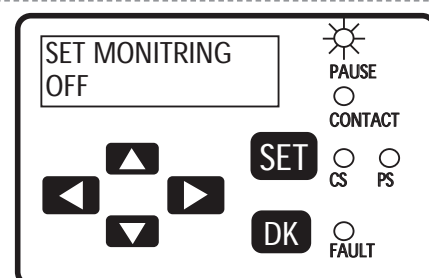

6. Press **SET** to confirm the new settings.

7. LCD begins flashing to remind user all new settings are confirmed. Then press **SET** without releasing, LCD stops flashing; 2 seconds later, the new values are saved permanently and display goes out.

Note: If press **SET** shorter than 2 seconds, the control unit will give up new settings and go back to the initial state of PROGRAMMING.

4.4 Change PAUSE and CONTACT control mode (Carry out steps 1-2)

3. Continually press **▲** till "SET CONTROL MODE" is displayed on the second line of the LCD, and LED "PAUSE" and "CONTACT" flash.

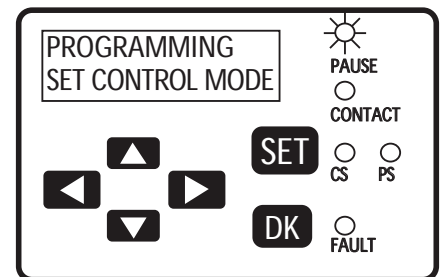

4. Briefly press **SET** to get into pause mode setting. LED "PAUSE" flashes. The current pause mode is displayed. Example: TIMER (Factory setting)

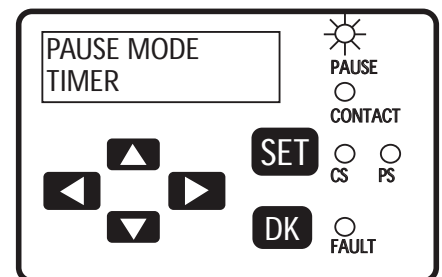

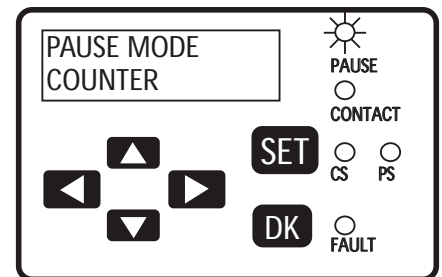

5. Press **▲** or **▼** to change pause mode. Example: COUNTER

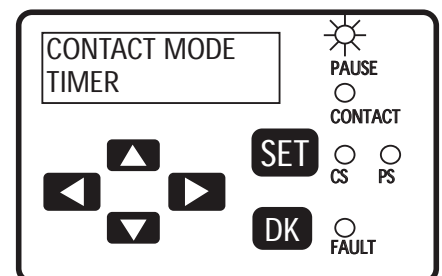

6. Press **SET** to confirm the new PAUSE mode. LED "PAUSE" goes out and LED "CONTACT" flashes. The preset contact mode is displayed. Example: TIMER



7. Press  or  to change contact mode.
Example: COUNTER

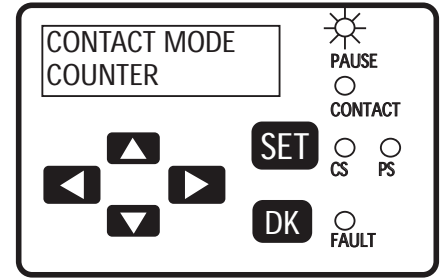

8. Press  to confirm the new contact mode.

9. LCD flashes to remind user all new settings are confirmed. Then press  without releasing, LCD stops flashing; 2 seconds later, the new values are saved permanently and display goes out.

Note: If press  shorter than 2 seconds, the control unit will give up new settings and go back to the initial state of PROGRAMMING

Please note: after the control mode of PAUSE or CONTACT being changed, the new control parameter should be set according to the requirement of actual lubrication task.

4.5 Change password (Carry out steps 1-2)

Once the password is changed, the password set by factory will be erased.
The new password is saved till next change.

3. Continually press  till "SET PASSWORD" is displayed on the second line of the LCD.

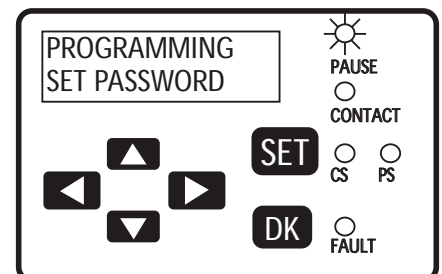

4. Briefly press  to get into SET PASSWORD status, LCD displays current password.
Example: 0000 (Factory setting)

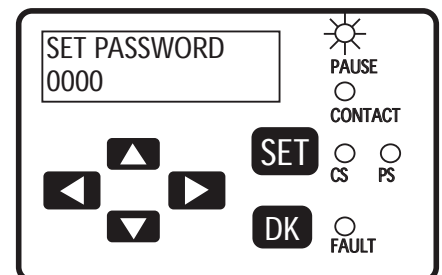

5. Edit 4 digits new password.
Example: 6666
The password range of **AF-1** is 0000 to 9999.
Control unit has no limitation within this area.

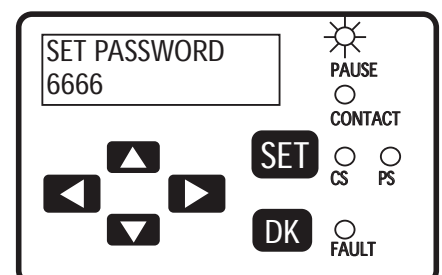

6. Press **SET** to confirm the new password.

7. LCD flashes to remind user the new password is confirmed. Then press **SET** without releasing, LCD stops flashing; 2 seconds later, the new values are saved permanently and display goes out.

Note: If press **SET** less than 2 seconds, the control unit will give up new password and go back to the initial state of PROGRAMMING.

Please note:

The password should be kept in a safe place. If the password gets lost, the programming of parameters for the control unit is impossible. In case of that, please contact manufacturer. Manufacturer's contact information is printed on fly page of the User's Manual.

5. Operating modes

5.1 Timer operation

Set "TIMER" for PAUSE and CONTACT.

The control of the lubrication cycle takes place based on the values preset for PAUSE and CONTACT times. It carries out the operation cycle of "PAUSE - CONTACT".

Press **DK**, an intermediate lubrication cycle is activated OR the displayed fault message is cleared. External DK button can be connected to the terminal DK/MK.

5.2 Counter operation (Pause depends on impulses)

Set "Counter" for PAUSE and "Timer" for CONTACT.

Connect an external impulse transmitter to the terminal KD/MK.

PAUSE: Display and program values in impulses.

CONTACT: Display and program values in minutes.

This operating mode is only used in connection with pump units filling level monitoring W1.

5.3 Combination operation (Pump running is controlled by external impulse)

PAUSE: Display and program values in impulses or time.

CONTACT: Display and program values in impulses.

Users may combine "COUNTER MODE" of pause with "COUNTER MODE" of contact, or "TIMER MODE" of pause with "COUNTER MODE" of contact.

5.4 Operation without system monitoring

The lubrication cycle performs only according to the preset values of PAUSE and CONTACT. Fault monitoring is disabled in this mode.

In this mode, the monitoring function must be disabled. Monitoring mode should be "OFF". Fault will not be automatically detected and displayed.

5.5 Operation with system monitoring

In this mode, system can be monitored by external switches.

The following functions can be monitored:

The filling level in the lubricant tank (only for pumps filling level monitoring W1).

The pressure build-up in the main line can be monitored via a pressure switch.

The function of the progressive feeder can be monitored via a cycle switch.

Faults will be automatically detected and displayed when system monitoring is activated.

5.6 Power-off protection function

The control unit has power-off protection function. When power is cut off, the control unit auto stores operating status, remain values, total operation time and total fault time at the point of power-off. When next electrify starts, the control unit will continue carrying out operation from last point of power-off.

The control unit stores operating status and values in EEPROM. The data can reliable be stored for 10 years.

6. Faults

When the control unit detects system faults, LED "FAULT" on the panel will be flashing quickly. If an external Signal Light has been installed, light "SL" will be also flashing to remind user the lubrication system is in fault. Meanwhile, the control unit stops normal operation and wait for user to handle the faults. User may check the detailed cause of the fault through LCD.

6.1 Display faults

Briefly press  or  to start the display of fault messages.

The meaning of the display are as followings:

PRESSURE SWITCH: No signal is received from pressure switch during pump running time.

CYCLE SWITCH: No signal is received from cycle switch during pump running time.

LOW LEVEL: The filling level in lubricant tank has dropped below the minimum level.

SYSTEM ERROR: the control unit itself has error inside. If such situation occurs, get the control unit power off, then get it power on 3s later. If error still exists, please contact the manufacturer.

6.2 Clear fault messages

Press  to acknowledge and clear fault messages, and to start a normal lubrication cycle.

Please note:  must been used after determining and correcting the faults. The user himself is liable for any damages caused by operating the equipment without lubrication.

6.3 Block operation

If CS (Cycle Switch) is programmed, a block operation will be automatically activated when no signal from the cycle switch is received during the pump running time. To test Cycle Switch:

1. When no signal from CS is received during the pump running period, the normal lubrication operation will be aborted, then a 15 min interval block operation begins.
2. When the 1st 15 min block interval ends, it drives the pump. If signal from CS is received, the block operation will be aborted. System goes back to normal lubrication cycle. If there is still no signal from CS, then another block operation begins.
3. If signal from CS is received during the 2nd 15 min interval, the block operation is aborted and the system will go back to normal operation. If there is no signal from CS, then the 3rd block operation begins.
4. If the system receives signals from CS during the 3rd 15 min interval, then it will go back to normal lubrication cycle. If there is still no signal received, then the block operation is aborted and a fault message is displayed.

If the preset PAUSE time is shorter than 15 min, the block pause will correspond to the preset value. During block operation, relevant LED on the control panel will be flashing to indicate that the control unit is now performing block operation. LED "CS" flashes alternative with LED "PAUSE" means the control unit is now in the Pause phase of the block operation. LED "CS" flashes alternative with LED "CONTACT" indicates the control unit is now in Drive phase of the block operation.

6.4 No signal from pressure switch

If PS (Pressure Switch) monitoring is programmed, normal operation will automatically stop when no signal from the pressure switch is received during the pump running. And a fault message is displayed.

6.5 Storage of fault messages

The time that has elapsed since the occurrence of the fault message up to its acknowledgement will be added up and saved automatically. And the saved fault time is not erasable. The maximum savable fault time is 999 999 hrs and 59 min. And the minimum savable fault interval is 1 minute.

7. Technical Data

Voltage of power supply?	10V~45V(wide voltage model)
Type of protection?	IP 40
Max. Load output M?	16A(wide voltage model)
SL output?	5W
Data storage:	No Limitation
Operation temperature:	-20 C° to 70 C°
Storage temperature:	-40 C° to 80 C°
Recommended fuse specification:	10 A (wide voltage model)
Installation dimensions L×W×H:	137mm x 92mm x 42mm
Single Mass:	200 g
Programmable contact time:	1 s to 17h 59min 59s
Programmable pause time:	1 min to 999h 59min
Programmable impulses?	1 to 59999
Operation time Memory:	0 to 999 999 h 59 min
Fault time Memory:	0 to 999 999 h 59 min

VERIFICATION OF EMC COMPLIANCE



Certificate No. AC/0290108

Applicant : FRITSCHÉ GmbH

Address of Applicant : NIEDERSACHSENWEG 36, 21244 BUCHHOLZ, GERMANY

Product Description : UNIVERSAL CONTROL UNIT OF CENTRAL LUBRICATION

Type and Model : AF-1

**Technical Construction File
Referenced No./Rev** : STT/08T1027-EMC

Codes/Standards Applied : EN 55022: 1998+A2: 2003; EN 55024: 1998+A2: 2003;
EN 61000-3-2:2000, EN 61000-3-3: 1995+A1: 2001

Date Of Issuance : Jan 23, 2008

Remarks : This Certificate Is Only Valid For The Equipment And Configuration
Described, And In Conjunction With The Test Data Detailed Above.

Conclusion of Assessment :

We Hereby Confirm That The Technical Construction File And Manufacturing, Inspection And Testing Processes For Above-Mentioned Equipment Comply With The Essential Safety Requirements Of EU Electromagnetic Compatibility Directive 2004/108/EC Applied Codes And Standards.

Chief Assessor:

A handwritten signature in black ink, appearing to read 'Patrick Wang', written over a circular stamp.

Anger Certification & Testing Service LTD.



AUGER CERTIFICATION & TESTING SERVICE LTD
SUITE 8525, 16-18 CIRCUS ROAD, ST. JOHN'S WOOD, LONDON, NW8 6PG
info@augeruk.org

